

Technical Data Sheet

Single Wall Grease Duct – In Stock!

STOCK SWGD

Product Line

STOCK SWGD – Single Wall Grease Duct



Applications

Stainless steel factory-built ductwork designed to be a direct replacement for 16 gage field-welded grease duct. Short SKU list assures in stock or quick lead time for almost any kitchen exhaust system.

SWGD taps together without the need for welding or in field fabrication.

Insulation wrap can be field installed with single layer for reduced clearance or 2 layers for zero-clearance and fire-rated enclosure.

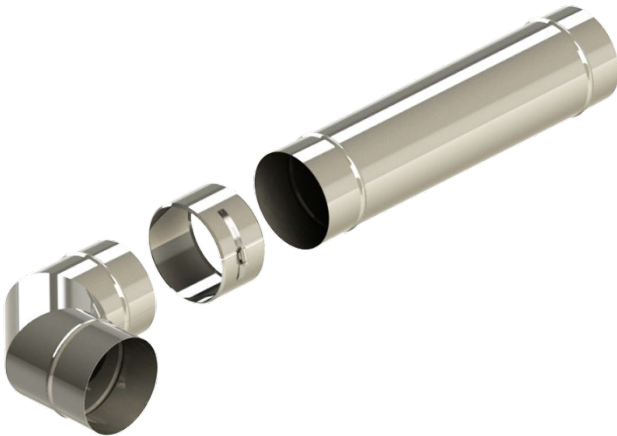

Purpose

Factory built eliminates welding in the field.

Assurance of finest quality and reliability.

Quick and easy inspections.

UL Listings (and ULC)

- UL-1978 Standard, Grease Duct (ULC-S662 Standard for Factory-Built Grease Ducts)
- UL-103 Standard, Building Heating Appliance Chimney (Industrial Type 540°C Chimney)
- UL-103 & UL-2561 Standards, Additional Positive Pressure Listing to 90" WC after 1400°F

Materials

- Pipe and fittings are made of stainless steel
- Laser seam welded pipe with tig welded fittings
- All supports and accessories are stainless steel as well

Connection / Installation Details

Conical 2.2" overlapping joint.

Requires tapping to fully engage.

Use KL-Paste, a ceramic and mineral oil based manufacturing paste, to help facilitate an easy engagement. Locking band will not fit unless joint is fully engaged.

Does NOT use silicone or sealant to make the high pressure 90" W.C. capability seal.

Features

- Pre-packaged Base Kits include key components for every GD installation (NWA, Paste, cut lengths, KLC Clamps and Fan Adapter plate)
- Field cuttable lengths for maximum flexibility in the field
- All-stainless with Limited Lifetime Warranty
- 3D VentBOM designs and Bill of Materials done in seconds
- Smooth flow and known resistance for perfected factory pressure calculations
- Field insulate as required for reduced or zero clearance

Technical Data Sheet

Single Wall Grease Duct – In Stock!

STOCK SWGD

Product Line
STOCK SWGD – Single Wall Grease Duct



Product Specifications

STOCK SWGD – Single Wall Grease Duct

Diameters	8", 10", 12", 14", & 16" stock diameters now (more in the future)
Available Lengths	12", 24", 36", & 48" fixed lengths / 18" & 30" field cutable lengths
Available Fittings	45° w/ access, 87° w/ access, & increasing bullhead tees
Available Accessories	No-weld hood connector, access doors, support hangers, & field cutable fan plate adapter

Base Kit

- KL-Paste, assembly Paste for easiest connections
- KLC, KL Clamp for assembly without pushing/tapping
- NWA, No Weld Hood Adapter
- LSB, Light Support Band
- 18CL, 18" field Cutable Length
- 30CL, 30" field Cutable Length
- FPE:36x36, Fan Plate with 36"x36" field cutable plate



Additional Items

Any Item above, plus

- 12L, 12" Length
- 24L, 24" Length
- 36L, 36" Length
- 48L, 48" Length
- 45EA, 45-degree Elbow with Access
- 87EA, 87-degree Elbow with Access
- IAD, Inline Access Door
- FC, Flange Collar w/ Vee Band for Hood Collar

