

SWCK

PRODUCT LINE

SWCK - Single Wall Commercial Kitchen Exhaust

APPLICATIONS

- Stainless steel duct for connecting cooking appliances, kitchen hoods, and dishwasher exhausts to the outdoors under negative or positive pressure
- A true replacement for field welded black steel
- Design eliminates welding and time-consuming inspections in the field
- Provides UL/ULC Listed and Certified exhaust solutions



PURPOSE

- Factory-built eliminates welding in the field
- Easiest and Fastest joint assembly on the market using innovative and industry first technology
- No vee bands means faster and easier installations
- Due to the unique joint design, every pipe length can be cut-to-fit in the field
- Can complete any project with 48\"
- Assurance of finest quality and reliability
- Quick and easy inspections

UL AND ULC LISTINGS

1. UL-1978 Standard, Grease Duct (ULC-S662 Standard for Factory-Built Grease Ducts)
2. UL-103 Standard, Building Heating Appliance Chimney
3. Additional UL/ULC 20\"

MATERIALS

- Made of high-grade stainless steel, thickness per UL-1978 Listing
- All supports and accessories are stainless steel

CONNECTION/INSTALLATION DETAILS

2.2\"

1. Use supplied silicone sealant to make the complete seal
2. Push the male/female ends together
3. Install the single-screw locking band

FEATURES

- Only 1/16\"
- Factory CAD designs for installation ease
- All lengths are field cuttable for maximum flexibility
- 100% Stainless Steel with Limited Lifetime Warranty
- Overlapping high pressure joints
- Smooth flow and known resistance for perfected factory pressure calculations



SWCK



PRODUCT LINE

SWCK – Single Wall Commercial Kitchen Exhaust

SPECIFICATIONS

Diameters	6", 7", 8", 9", 10", 11", 12", 13", 14", 16", 18", 20", 22", 24", 26", 28", 30", 32", 34", & 36" (use SWFL for diameters 38" through 48")
Available Lengths	9", 12", 18", 24", 30", 36", 42", & 48" (or any fixed length between)
Available Fittings	Any elbow or tee, over 80 catalog fittings per each diameter
Available Accessories	All-stainless supports, guides, hangers, adapters – over 25 accessories per diameter

SMART FITTINGS & ACCESSORIES

Besides the smart cut-to-fit technology, Jeremias uses smart fittings and accessories specifically designed for Grease Ducts. These include:

- 87° elbow with built-in access panel
- 45° elbow with built-in access panel
- Common wye with reduction branches
- No-weld hood connections

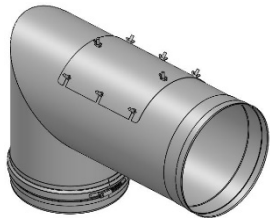

87-Degree Elbow with Access

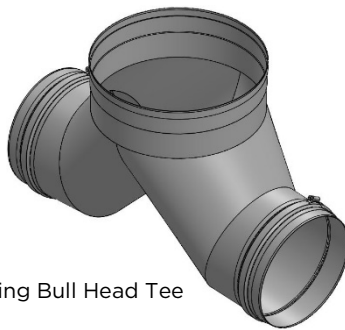

Increasing Bull Head Tee

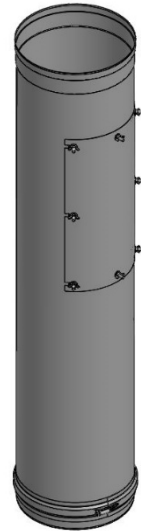

In Line Access Length

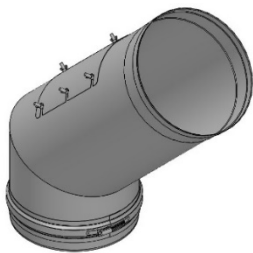

45-Degree Elbow with Access

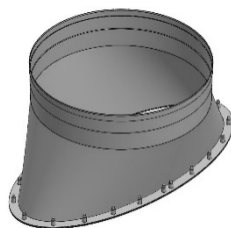

No-Weld Hood Adapter

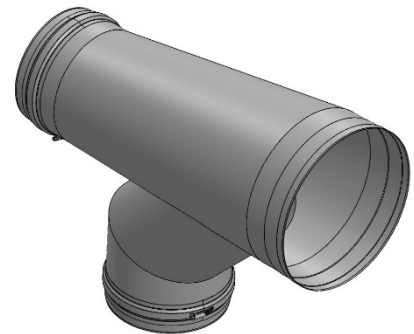

Increasing Boot Tee

