

# COMPANY PROFILE

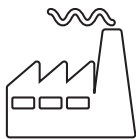

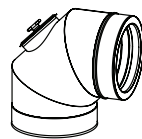

**8**  
Production sites



**83,000**  
References  
worldwide

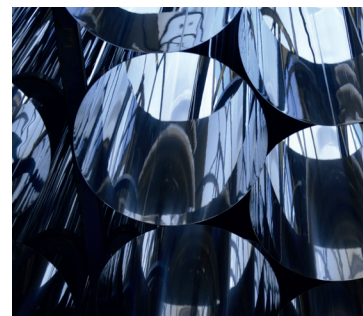

**1,400**  
Employees



**60**  
Countries



# A STRONG, OPEN AND INTERNATIONAL GROUP

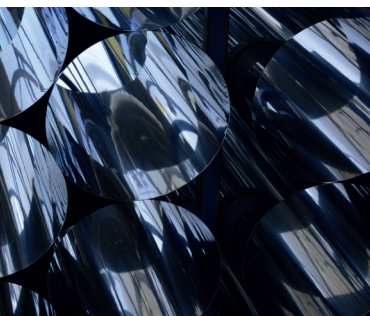

## WELCOME TO JEREMIAS GROUP

Jeremias Group has over 40 years of experience in design, production and development of solutions for exhaust systems. Headquartered in Germany, Jeremias is one of the world's leading manufacturers of factory made flue, chimney and ventilation systems covering all kinds of domestic, commercial and industrial applications.

The family-owned company now has 8 production sites in Europe and North America and is represented in more than 60 countries worldwide. Jeremias is a world leader in the production of factory made stainless steel flue and chimney systems as well as freestanding chimney systems.

Wide product range, more than 100 certified systems, after sales service and in-house developed chimney sizing make Jeremias the most dynamic company in the chimney sector. With Jeremias you can expect durable quality and continuous innovation.

# FROM A FAMILY BUSINESS TO A GLOBAL PLAYER

The Jeremias group dates back to the early 70's with the discovery of a niche sector in relining chimney systems due to the use of new technologies in the heating sector.

Chimney sweeper Walter Engelhardt together with his partner Johann Melzner founded a company dedicated to chimney relining.

Following the footsteps of his father, Stefan Engelhardt started with the industrial manufacturing of stainless steel flue and chimney systems and founded Jeremias GmbH in 1984. The beginning of an unprecedented success story!

This led to a fast and healthy growth of the company with subsequent opening of subsidiaries and addition of sales partnerships across the globe.

Still family-owned, Jeremias today is one of the world leaders in manufacturing of chimneys and flue systems and is actively working to strengthen its position as the most customer-orientated company in the market with innovative and high quality product solutions.

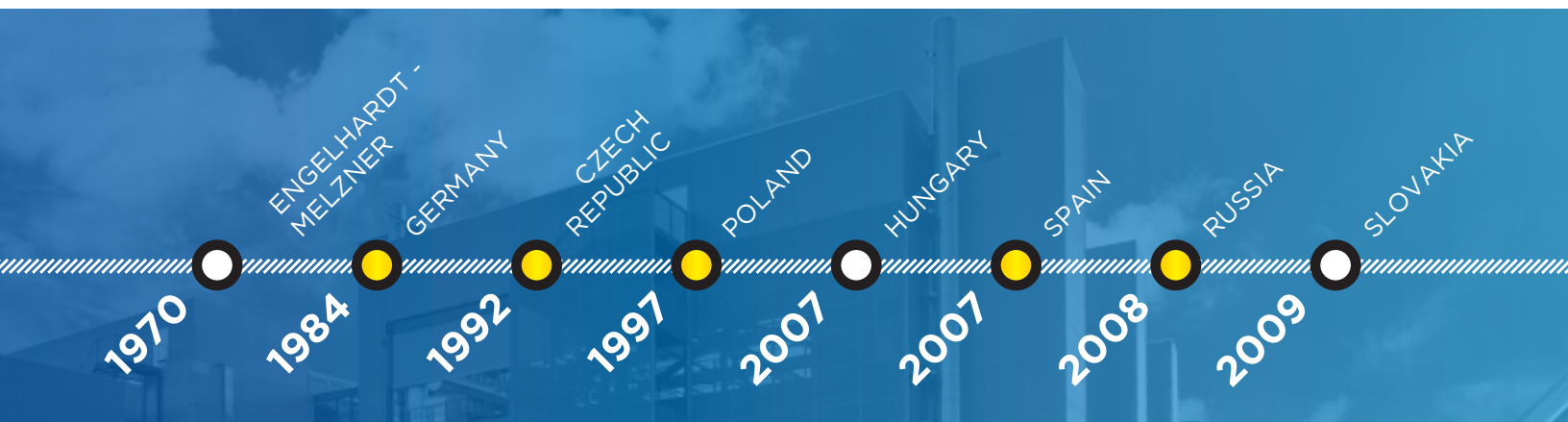

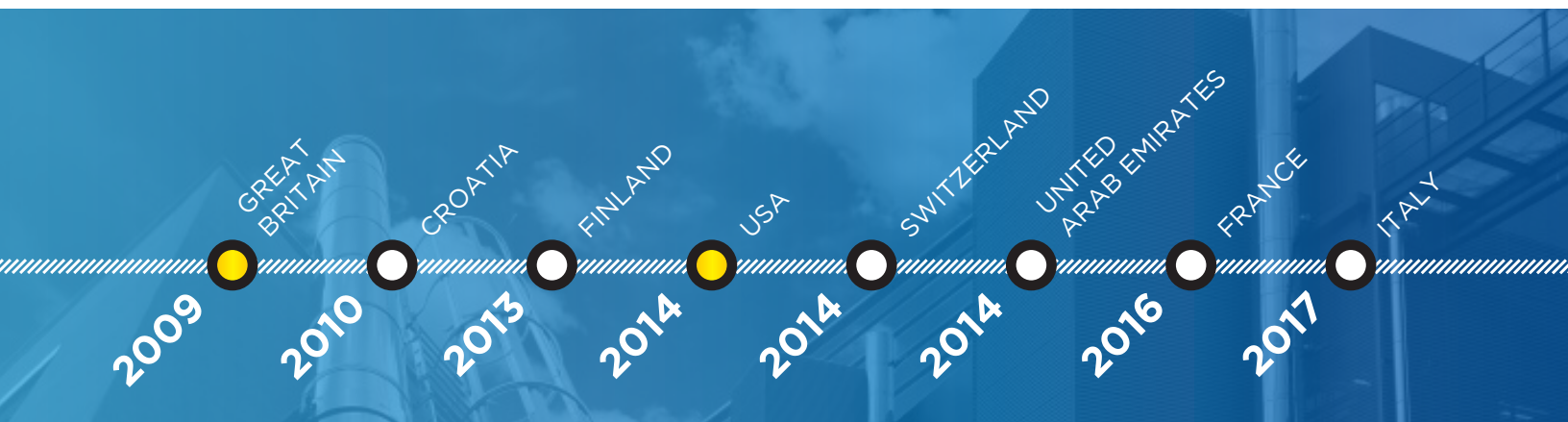

# GLOBAL PRESENCE AND PROXIMITY TO CUSTOMER



PRODUCTION SITES 

1. GERMANY

[www.jeremias.de](http://www.jeremias.de)

2. POLAND

[www.jeremias.pl](http://www.jeremias.pl)

3. SPAIN

[www.jeremias.com.es](http://www.jeremias.com.es)

4. RUSSIA

[www.jeremias.ru](http://www.jeremias.ru)

SALES OFFICES 

8. FRANCE

[www.jeremias-france.fr](http://www.jeremias-france.fr)

9. HUNGARY

[www.jeremias.hu](http://www.jeremias.hu)

10. SLOVAKIA

[www.jeremias.sk](http://www.jeremias.sk)

11. CROATIA

[www.jeremias.hr](http://www.jeremias.hr)

REALIZED PROJECTS 

Since its inception, the philosophy of the Jeremias Group has been characterized by a gradual, consistent and strong spirit of expansion. With eight production facilities worldwide, eight subsidiaries and numerous sales partners nationally and internationally, we can guarantee our customers optimal service as well as permanent and location-independent accessibility. Thousands of projects realized worldwide gives a clear message: we are always and everywhere there for you!



**5. CZECH REP.**  
[www.jeremias.cz](http://www.jeremias.cz)

**6. USA**  
[www.jeremiasinc.com](http://www.jeremiasinc.com)

**7. GREAT BRITAIN**  
[www.jeremias-fluesystems.co.uk](http://www.jeremias-fluesystems.co.uk)

**12. FINLAND**  
[www.jeremias.fi](http://www.jeremias.fi)

**13. SWITZERLAND**  
[www.jeremias-schweiz.ch](http://www.jeremias-schweiz.ch)

**14. UNITED ARAB EMIRATES**  
[www.jeremias-me.com](http://www.jeremias-me.com)

**15. ITALY**  
[www.jeremias.it](http://www.jeremias.it)

# A COMPLETE PRODUCT RANGE – ONE-STOP-SHOP

As a leader in exhaust technology, we develop innovative systems for a wide variety of applications and markets. We offer our customers the most diverse choice of products in the industry and a complete range from easy-to-install modular systems to freestanding steel chimneys.



SINGLE WALL LINING SYSTEMS



DOUBLE WALL SYSTEMS



COMMON VENTED SYSTEMS

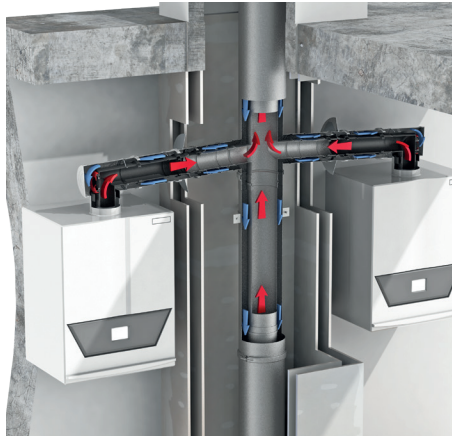

DIRECT VENT FOR GAS FIREPLACES



TYPE HT CHIMNEY



PELLET VENT



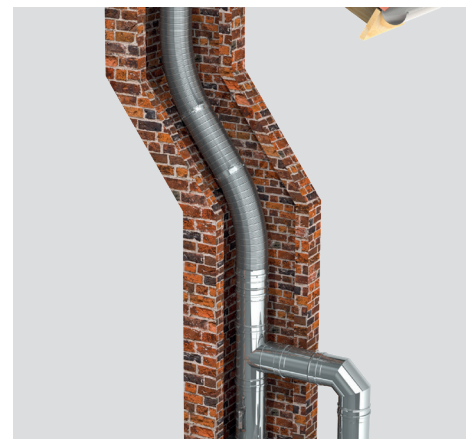
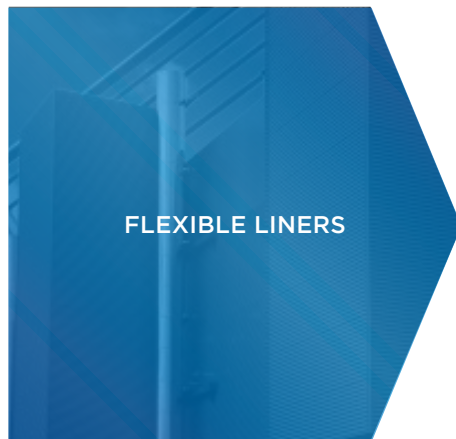

SILENCERS



CUSTOM TERMINATIONS

LAUNDRY SHAFTS



DAMPERS

VENTILATION SYSTEMS



VENTILATION TOWERS

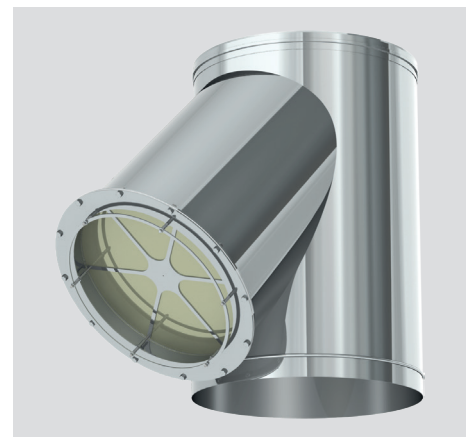

# COMMERCIAL EXHAUST SYSTEMS

Commercial applications require pressure tightness and high temperatures. Jeremias offers a wide range of exhaust systems designed to extract combustion gases from generators, CHPs, ovens, condensing boilers, pressurized boilers, etc. These systems are also perfect for air supply and ventilation applications.

## DWKL / SWKL

DWKL (double wall) and SWKL (single wall) conical systems incorporate a pressure-tight steel to steel conical joint and clamp system for quick and easy assembly on the site. The conical steel to steel contact at each connection allows high stiffness, sealing, and durability. Because no silicone sealant is required, the system is perfect for applications with high exhaust temperatures.

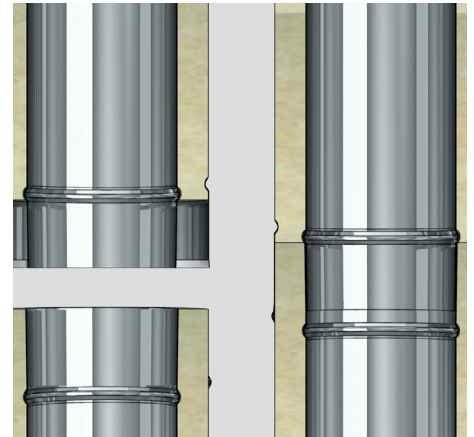

## DWFL / SWFL

DWFL is a hybrid system which combines the best of the World Class DWKL features with the assembly ease of flanged Pressure Stack systems. The stainless steel construction has a conical joint and is available with ceramic fiber insulation in various thickness options. A flange socket is secured by a V-band mechanism which ensures a rigid connection. Model SWFL is the inner only (single wall) of model DWFL.

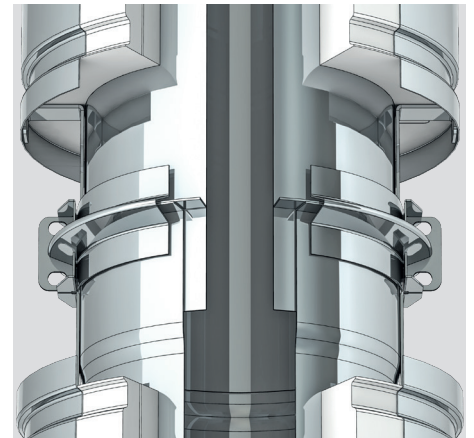

## DWGV / SWGV

DWGV (double wall) and SWGV (single wall) Special Gas Vent systems incorporate industry leading 2.2" overlapping joint and integrated 3-ribbed silicone gasket. Both models are UL-1738 and ULC-S636 Listed for use with condensing appliances and are very easy to install.

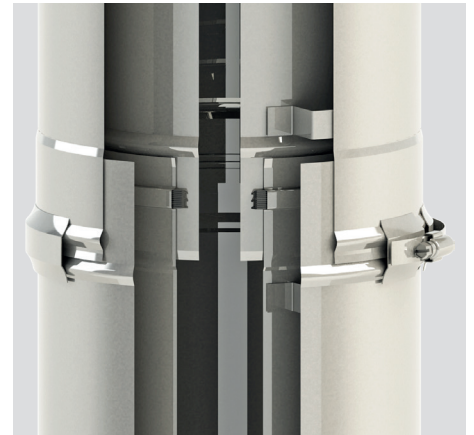

## DWHT - 103HT ALL FUEL CHIMNEY

DWHT is a double walled stainless steel exhaust system specifically designed for solid fuel residential type applications. Industry leading materials deliver true "All Fuel" performance and include 316L or 444 stainless inner wall, 304 bright annealed outer and rigid high-density mineral fiber insulation. Class leading design elements include NO connective spacing elements between inner/outer wall (NO thermal bridge!), longest joint overlap of 2.25", all stainless supports, and strong attractive locking bands that install easily and provide a clean finished appearance. German designed, American made.



# SUITABLE SOLUTIONS FOR A WIDE RANGE OF APPLICATION AREAS

As one of the world's leading manufacturers, Jeremias offers exhaust and ventilation chimney systems for a wide range of applications in the private, commercial and industrial sectors. No matter what purpose it serves, Jeremias has the right solution!



DOMESTIC AND RESIDENTIAL SOLUTIONS



CHIMNEY RELINING



CONDENSING BOILERS



COMMERCIAL SOLUTIONS



KITCHEN EXHAUST

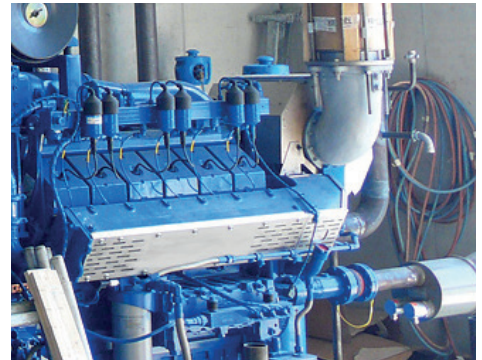

CHPS



INDUSTRIAL SOLUTIONS



GAS TURBINES



STEAM BOILERS



STOVES AND FIREPLACES



GAS FIREPLACES

- BIOMASS BOILERS
- HEAT-RECOVERY VENTILATION



CONDENSING BOILERS



GENERATORS

- PACKAGE PLANTROOMS
- GAS OIL AND BIOMASS BOILERS
- VENTILATION



MARITIME APPLICATIONS



ENGINE TEST STANDS

- EMERGENCY BACKUP GENERATORS
- INDUSTRIAL VENTILATION
- INDUSTRIAL KITCHEN EXHAUST

# WE REALIZE PROJECTS FOR DIFFERENT INDUSTRIES

In the last 40 years, Jeremias has produced tens of thousands of projects worldwide. We offer solutions for all applications and all energy sources with efficient exhaust systems. Whether the demand is for production plants, data centers, clinics, hotels, football stadiums or public facilities, Jeremias exhaust systems are the perfect solution.







PIZZA OVENS



APARTMENT HOUSES



STADIUMS



AUTOMOTIVE INDUSTRY



INDUSTRIAL BAKERIES

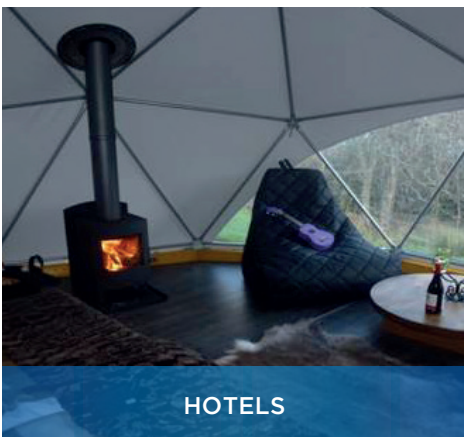

HOTELS



POWER PLANTS



SHOPPING CENTERS



HOTELS



COFFEE ROASTERIES



PAPER INDUSTRY



UNIVERSITIES



FOOD INDUSTRY



INCINERATORS



INDUSTRIAL KITCHENS



INDUSTRIAL VENTILATION



FAMILY HOMES



PIZZA OVENS



OIL PLATFORMS

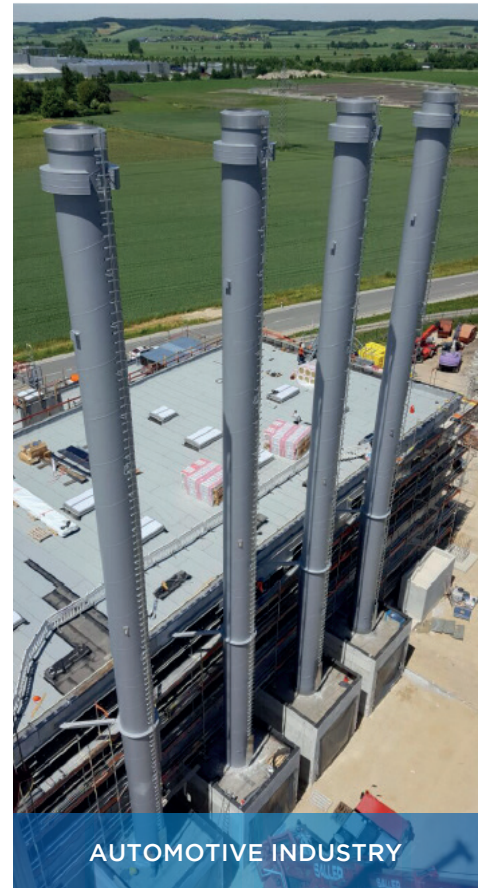

AUTOMOTIVE INDUSTRY



INDUSTRIAL BAKERIES



STADIUMS



FAMILY HOMES



HEATING UNITS



GEOHERMAL INDUSTRY

- BREWERIES
  - RAILWAY STATIONS
  - PUBLIC BUILDINGS
  - PORTS
  - CRUISE SHIPS
  - AIRPORTS
  - EXHIBITION CENTERS
  - MUSEUMS
  - CONFERENCE CENTERS
  - SCHOOLS
  - THEATERS
  - SWIMMING POOLS
- ... AND MUCH MORE:  
[www.jeremiasinc.com/references](http://www.jeremiasinc.com/references)

# EXPECT ONLY THE BEST FROM US!

## MORE QUALITY

The top quality of Jeremias products is based on the deep-seated quality awareness of our employees. We maintain a quality management system for the continuous optimization of products, processes and activities. Our own test facilities as well as externally monitored production controls ensure a consistent high quality standard. In addition to mandatory standards and certifications, Jeremias exhaust systems also meet national and application specific norms.

## MORE SERVICE

We are partners of our customers and we want to inspire them every day with our outstanding service. We continue to develop in partnership with our customers and set the highest standards in the industry with expert advice, unique flexibility and a passion to meet even the most complex individual demands.

## MORE INNOVATION

As a technology leader, we always strive for innovative product range additions and further expand our systems to meet the needs of our customers. In cooperation with the manufacturers of heat generators and fireplaces, we are developing new systems and product solutions according to market trends for new application areas.





# A FAIR AND RELIABLE PARTNER

## OUR CUSTOMERS

The basis of our many years of success is the company's philosophy based on tradition and values.

Our customers can rely on our professional support, many years of experience and expert advice. As a family-owned company, we are a trusted and reliable partner. The relationships with our business partners are usually long lasting, and are characterized by constructive and fair cooperation.

## OUR EMPLOYEES

The extraordinary achievements of our employees are one of the main success factors for Jeremias. We don't consider our work as a routine. We consider our work to be special, and provide an optimal solution to our customers with competence and personal commitment.

In doing so, we rely on open and trustworthy communication. We offer excellent personal development opportunities to our employees in order to form better teamwork.





## PRODUCTION SITES

### USA

Jeremias Inc.  
983 Industrial Park Drive  
Marietta, GA 30062, USA  
phone: +1 678 388 2740  
e-mail: [info@jeremiasinc.com](mailto:info@jeremiasinc.com)  
[www.jeremiasinc.com](http://www.jeremiasinc.com)

### GERMANY

[www.jeremias.de](http://www.jeremias.de)

### POLAND

[www.jeremias.pl](http://www.jeremias.pl)

### SPAIN

[www.jeremias.com.es](http://www.jeremias.com.es)

### RUSSIA

[www.jeremias.ru](http://www.jeremias.ru)

### CZECH REPUBLIC

[www.jeremias.cz](http://www.jeremias.cz)

### UNITED KINGDOM

[www.jeremias.uk](http://www.jeremias.uk)

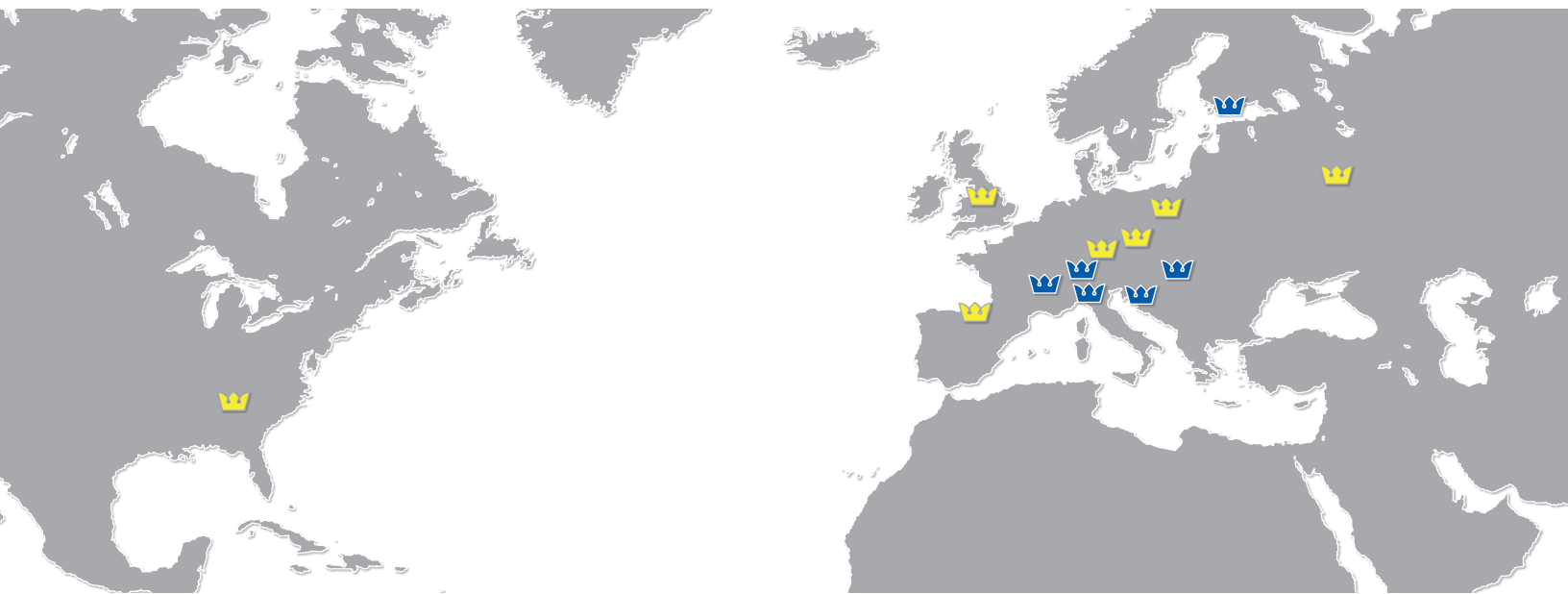

## SALES OFFICES

### FRANCE

[www.jeremias-france.fr](http://www.jeremias-france.fr)

### HUNGARY

[www.jeremias.hu](http://www.jeremias.hu)

### CROATIA

[www.jeremias.hr](http://www.jeremias.hr)

### FINLAND

[www.jeremias.fi](http://www.jeremias.fi)

### SWITZERLAND

[www.jeremias-schweiz.ch](http://www.jeremias-schweiz.ch)

### ITALY

[www.jeremias.it](http://www.jeremias.it)

## JEREMIAS IS REPRESENTED IN THE FOLLOWING COUNTRIES:

Austria | Belarus | Belgium | Bulgaria | Brazil | Denmark | Estonia | Hong Kong | Ireland | Kazakhstan | Latvia | Lithuania | Luxembourg | Malta | Netherlands | Norway | Portugal | Romania | Saudi Arabia | Serbia | Singapore | Slovakia | Slovenia | South Africa | Sweden | Tunisia | UAE | Ukraine

The expert in your area:

Jeremias high quality products to be installed only by selected experts.